



Large Display with Blue Backlight



Small Tray & Windshield for protection

MWPP SERIES

High Precision Balance

The MWP Micro Weighing Scale weighs in small increments making it very accurate. Large high contrast blue backlight LCD display. Total of 8 Switchable Units available. Counting, Weighing, Percentage Function Modes. MWP can also connect to a PC or Printer. Ideal for hospital, pharmaceutical, & jewelry applications.

- High Accuracy
- Built-in Rechargeable Battery
- Total 8 Units available
(g, ct, lb, oz, GN, ozt, dwt, tl)
- Counting, Weighing, Percentage Function Modes
- Auto Blue Backlight
- RS-232 Serial Interface
(PC, Printer)
- Windshield Included



MWP SERIES | High Precision Balance

SPECIFICATIONS

Model	MWP-N			MWP-H		
	Max. Capacity (g)	300	600	3000	300	600
Readability (g)	0.01	0.02	0.1	0.005	0.01	0.05
External Resolution	1/30,000 ~ 1/60,000					
Display Digit	6 Digits (Weight)					
Display Type	LCD with Backlight					
Operating Temp.	0°C~40°C					
Power	AC Adapter 12V, DC/500mA, Internal rechargeable lead acid batter					
Platter Size	300~600g: ø116 mm 3000g: 144mm(W) x 124mm(D)					
Dimensions	200mm(W) x 250mm(D) x 80mm(H)					
Product Weight	1.3 kg			1.4 kg		

DIMENSIONS

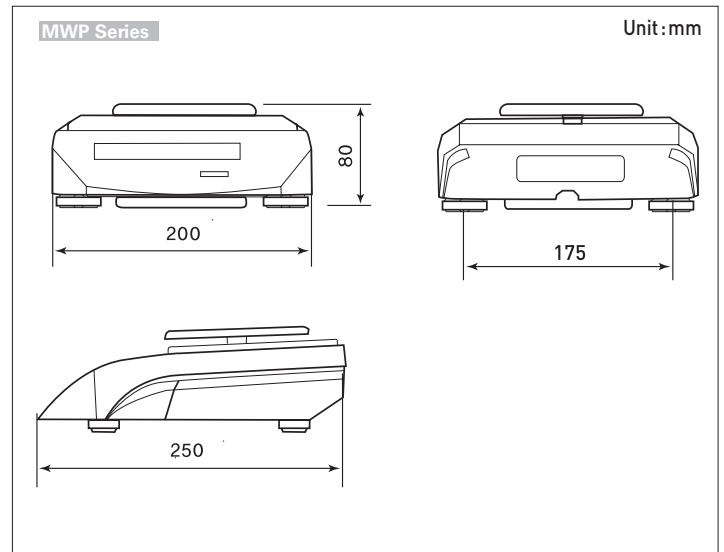

FEATURES

- High Accuracy
- Total 8 Units Available
(g, ct, lb, oz, GN, ozt, dwt, tl)
- Counting, Weighing, Percentage Function Modes
- Auto Blue Backlight (80hrs Continuous Use)
- Built-in Rechargeable Battery
- RS-232 Serial Interface (PC, Printer)
- Wind Shield Included
- Overload Alarm Function
- Auto Power Off Function
- Auto Span Calibration & Auto Zero Tracking

MODELS



MWP High Capacity



MWP Low Capacity

CAS

UNIT 8, NORTHLINK, 459 TUFNELL ROAD
BANYO QLD 4014, AUSTRALIA
TEL: +61 7 3267 7767 FAX: +61 7 3267 1818
EMAIL: sales@cassscale.com.au
www.cassscale.com.au

Specifications are subject to change for improvement without prior notice.